

LECTURE NOTES
ON
CONSTRUCTION PROJECT MANAGEMENT

Emad Elbeltagi, Ph.D., P.Eng.,
Professor of Construction Engineering and Management

Construction Project Management

2016

Copyright © 2016 by the author. All rights reserved. No part of this book may be reproduced or distributed in any form or by any means, or stored in a data base or retrieval system, without the prior written permissions of the author.

PREFACE

In the Name of ALLAH the Most Merciful, the Most Compassionate

All praise is due to ALLAH and blessings and peace be upon His messenger and servant, Muhammad, and upon his family and companions and whoever follows his guidance until the Day of Resurrection.

Construction project management is a relatively young field. However, its impact has been quite remarkable. It has become an important practice for improving the efficiency of construction operations around the world. This book deals with some topics and tools of the large field of project management.

This book is dedicated mainly to undergraduate engineering students, especially Civil Engineering students where most of the applications are presented in the civil engineering field. It provides the reader with the main knowledge to manage a construction project from preliminary stages to handover. It includes seven chapters: Chapter 1 provides the planning stages of a construction project. Chapter 2 is dedicated for presenting different scheduling techniques along with the schedule representation. Chapter 3 is dedicated to discuss the scheduling methods linear and repetitive activities projects. Chapter 4 is dealing with both the resource scheduling and smoothing problems. The schedule compression is, also, presented in chapter 5. Chapter 6 is dedicated for the project finance and cash flow analysis. Finally, chapter 7 is dedicated for project control. Many solved examples have been added to enable the students to understand the material presented in this book. Also, each chapter is followed by exercises for training purposes.

Finally, May ALLAH accepts this humble work and I hope it will be beneficial to its readers.

TABLE OF CONTENTS

CHAPTER 1: PROJECT PLANNING

1.1 Introduction	1
1.2 Project Planning Steps	2
1.2.1 Work Breakdown Structure (WBS)	3
1.2.2 Project Activities	7
1.2.3 Activities Relationships	11
1.2.4 Drawing Project Network	17
1.3 Estimating Activity Duration and Direct Cost	24
1.4 Exercises	27

CHAPTER 2: PROJECT SCHEDULING

2.1 The Critical Path Method	34
2.2 Calculations for the Critical Path Method	35
2.2.1 Activity-On-Arrow Networks Calculations	35
2.2.2 Precedence Diagram Method (PDM)	42
2.3 Time-Scaled Diagrams	45
2.4 Schedule Presentation	47
2.5 Criticisms to Network Techniques	48
2.6 Solved Examples	49
2.7 Exercises	53

CHAPTER 3: SCHEDULING OF REPETITIVE PROJECTS

3.1 Linear Projects	59
3.2 Resource-Driven Scheduling	60
3.3 Summary Diagrams	60

3.4 Line of Balance (LOB)	63
3.4.1 Basic Representation	63
3.4.2 LOB Calculations	65
3.5 Exercises	74
CHAPTER 4: RESOURCES MANAGEMENT	
4.1 Resource Definition	76
4.2 Resource Management	77
4.3 Resource Allocation	79
4.4 Resource Aggregation (Loading)	79
4.5 Resource Leveling (Smoothing)	81
4.6 Scheduling with Limited Resource	90
4.8 Exercises	95
CHAPTER 5: PROJECT TIME-COST TRADE-OFF	
5.1 Time-Cost Trade-Off	98
5.2 Activity Time-Cost Relationship	99
5.3 Project Time-Cost Relationship	103
5.4 Shortening Project Duration	104
5.5 Exercises	114
CHAPTER 6: PROJECT CASH FLOW	
6.1 Contract Cash Flow	116
6.1.1 Construction Project Costs	117
6.1.2 The S-Curve	120
6.1.3 Project Income (Cash-in)	122
6.1.4 Calculating Contract Cash Flow	124
6.1.5 Minimizing Contractor Negative Cash Flow	129
6.1.6 Cost of Borrowing (Return on Investment)	131
6.2 Project Cash Flow	136
6.2.1 Project Profitability Indicators	137

6.4 Exercises	139
CHAPTER 7: PROJECT CONTROL	
7.1 Problems that may Arise During Construction	142
7.2 Schedule Updating	143
7.3 Delays Analysis	147
7.3.1 Types of Delays	147
7.3.2 The As-Built Schedule	149
7.3.3 Analysis of Concurrent Delays	150
7.4 Earned Value Management	153
7.5 Exercises	159
REFERENCES	161

CHAPTER 1

PROJECT PLANNING

This chapter deals with preparing projects plans in terms of defining: work breakdown structure, activities, logical relations, durations and activities direct cost. Terminology of project planning will be presented and discussed. Project network representation using different graphical methods including: activity on arrow and activity on node are presented.

1.1 Introduction

Planning is a general term that sets a clear road map that should be followed to reach a destination. The term, therefore, has been used at different levels to mean different things. Planning involves the breakdown of the project into definable, measurable, and identifiable tasks/activities, and then establishes the logical interdependences among them. Generally, planning answers three main questions:

What is to be done?

How to do it?

Who does it?

In construction, for example, plans may exist at several levels: corporate strategic plans, pre-tender plans, pre-contract plans, short-term construction plans, and long-term construction plans. These plans are different from each other; however, all these plans involve four main steps:

- Performing breakdown of work items involved in the project into activities.
- Identifying the proper sequence by which the activities should be executed.
- Activities representation.
- Estimating the resources, time, and cost of individual activities.

Detailed planning for tendering purposes and the preparation of construction needs to be conducted through brainstorming sessions among the planning team. The inputs and outputs of the planning process are shown in [Figure 1.1](#).

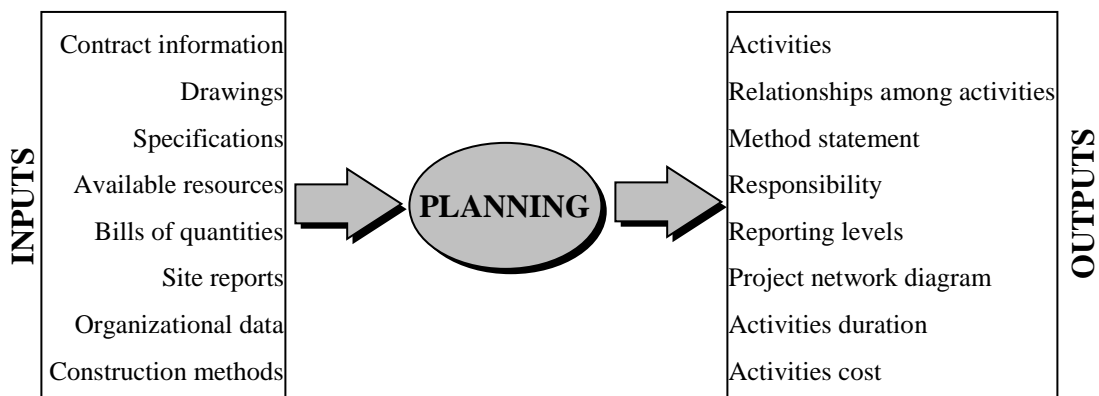

Figure 1.1: Planning inputs and outputs

Planning requires a rigorous effort by the planning team. A planner should know the different categories of work and be familiar with the terminology and knowledge used in general practice. Also, the planning team should seek the opinion of experts including actual construction experience. This helps produce a realistic plan and avoids problems later on site.

1.2 Project Planning Steps

The following steps may be used as a guideline, or checklist to develop a project plan:

1. Define the scope of work, method statement, and sequence of work.
2. Generate the work breakdown structure (WBS) to produce a complete list of activities.
3. Develop the organization breakdown structure (OBS) and link it with work breakdown structure to identify responsibilities.

4. Determine the relationship between activities.
5. Estimate activities time duration, cost expenditure, and resource requirement.
6. Develop the project network.

1.2.1 Work Breakdown Structure (WBS)

The WBS is described as a hierarchical structure which is designed to logically sub-divide all the work-elements of the project into a graphical presentation. The full scope of work for the project is placed at the top of the diagram, and then sub-divided smaller elements of work at each lower level of the breakdown. At the lowest level of the WBS the elements of work are called work packages. A list of project's activities is developed from the work packages.

Effective use of the WBS will outline the scope of the project and the responsibility for each work package. There is not necessarily a right or wrong structure because what may be an excellent fit for one discipline may be an awkward burden for another. To visualize the WBS, consider [Figure 1.2](#) which shows a house construction project.

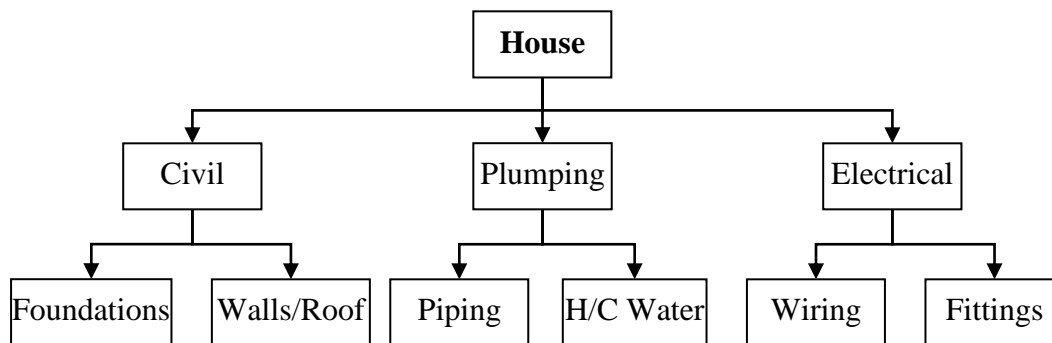

Figure 1.2: WBS and their description

As shown in [Figure 1.2](#), level 1 represents the full scope of work for the house. In level 2, the project is sub-divided into its three main trades, and in level 3 each trade is sub-divided to specific work packages. [Figure 1.3](#) shows another example for more detailed WBS, in which the project WBS is divided into five levels:

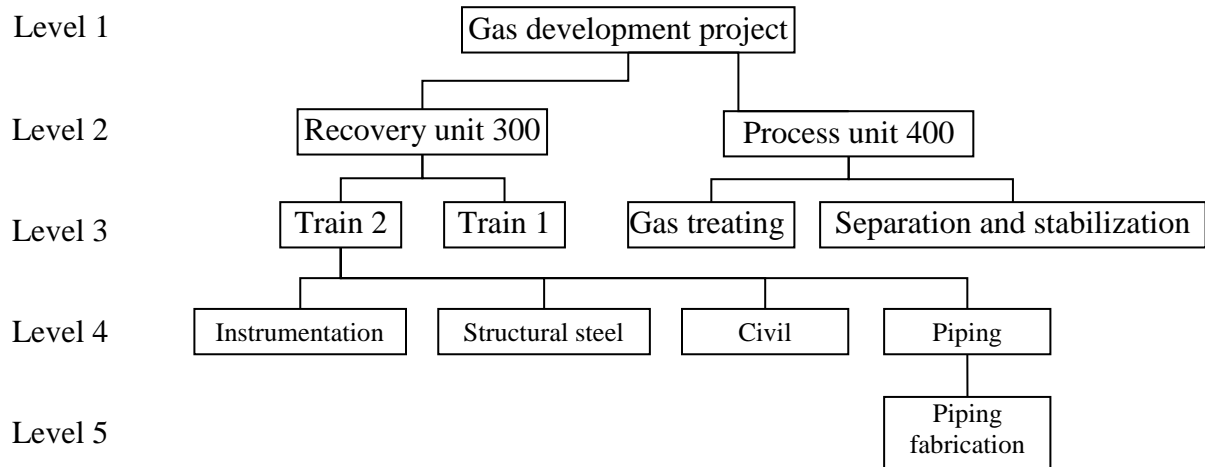

Figure 1.3: Five levels WBS

Level 1: The entire project.

Level 2: Independent areas.

Level 3: Physically identifiable sections fully contained in a level 2 area, reflect construction strategy.

Level 4: Disciplines set up schedule.

Level 5: Master schedule activities, quantity, duration.

Example 1.1:

The WBS for a warehouse is as follow:

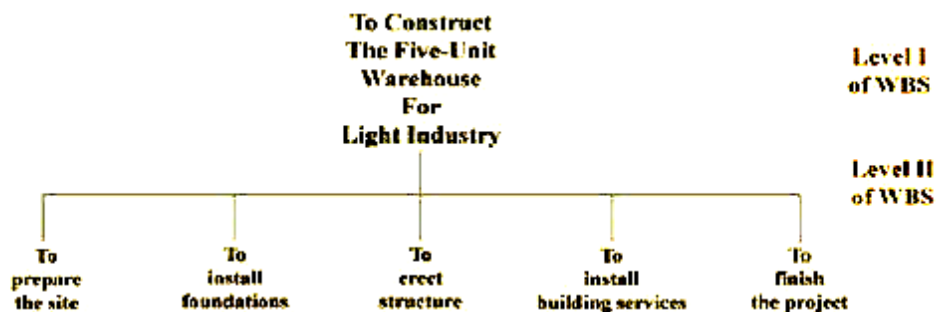

For more details, another two levels (third and fourth levels) can be added as shown below:

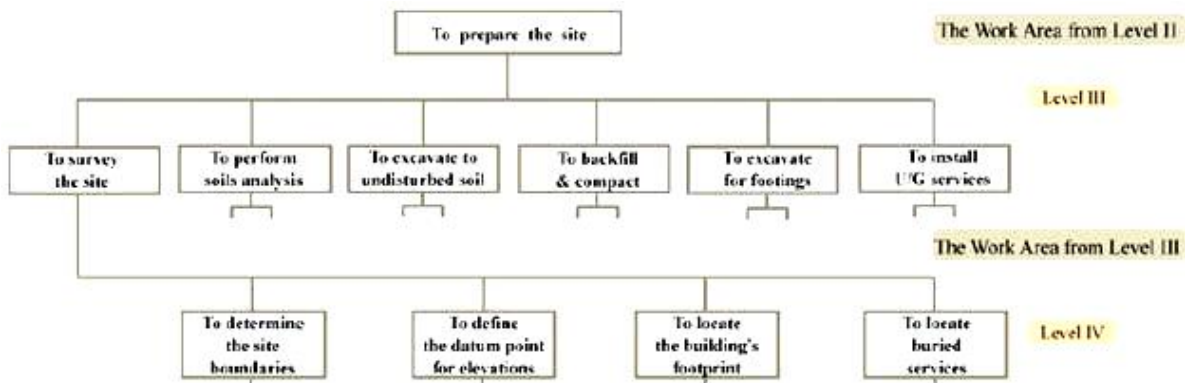

Accordingly, a complete WBS for the warehouse project can be shown as follow (Figure 1.4):

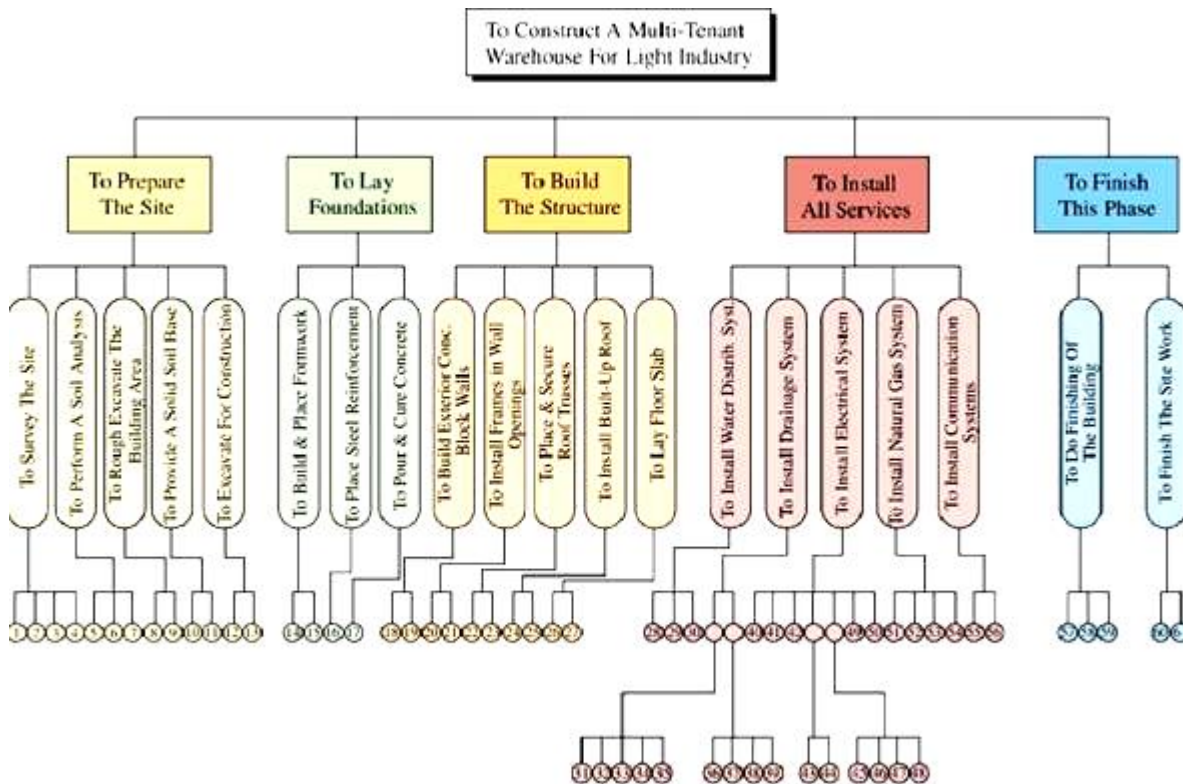

Figure 1.4: Warehouse project WBS

WBS and organizational breakdown structure (OBS)

The WBS elements at various levels can be related to the contractor's organizational breakdown structure (OBS), which defines the different responsibility levels and their appropriate reporting needs as shown in [Figure 1.5](#). The figure, also, shows that work packages are tied to the company unified code of accounts. The unified code of accounts allows cataloging, sorting, and summarizing of all information. As such, the activity of installing columns formwork of area 2, for example, which is the responsibility of the general contractor's formwork foreman, has a unique code that represents all its data.

WBS coding

A project code system provides the framework for project planning and control in which each work package in a WBS is given a unique code that is used in project planning and control. The coding system provides a comprehensive checklist of all items of work that can be found in a specific type of construction. Also, it provides uniformity, transfer & comparison of information among projects. An example of this coding system is the MasterFormat ([Figure 1.6](#)) which was developed through a joint effort of 8 industry & professional associations including: Construction Specifications Institute (CSI); and Construction Specifications Canada (CSC). [Figure 1.7](#) shows an example of the coding system using a standardize system as the MasterFormat. The Master format is divided into 16 divisions as follows:

- 1) General Requirements.
- 2) Site work.
- 3) Concrete.
- 4) Masonry.
- 5) Metals.
- 6) Woods & Plastics.
- 7) Thermal & Moisture Protection.
- 8) Doors & Windows.
- 9) Finishes.

- 10) Specialties.
- 11) Equipment
- 12) Furnishings.
- 13) Special Construction.
- 14) Conveying Systems.
- 15) Mechanical.
- 16) Electrical.

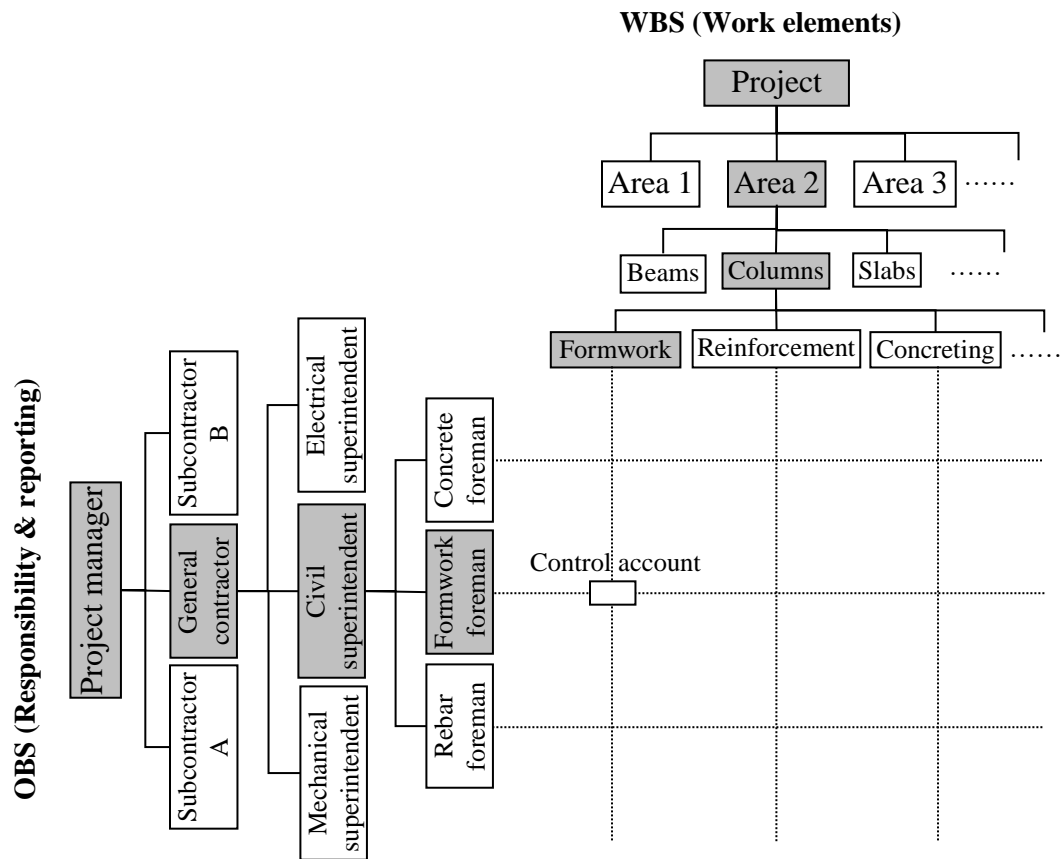

Figure 1.5: WBS linked to the OBS

1.2.2 Project Activities

The building block (the smallest unit) of a WBS is the activity, which is a unique unit of the project that has a specified duration. An activity is defined as any function or decision in the project that: consumes time, resources, and cost. Activities are classified to three types:

00010 Pre-bid Information
 00100 Instructions to Bidders
 00200 Information available to Bidders
 00300 Bid Forms
 00400 Supplements to Bid Forms
 00500 Agreement Forms
 00600 Bonds and Certificates
 00700 General Conditions
 00800 Supplementary Conditions
 00900 Addenda

Note: The items listed above are not specification sections and are referred to as "Documents" rather than "Sections" in the Master List of Section Titles, Numbers, and Broadscope Section Explanations.

Specifications

Division 1 - General Requirements

01010 Summary of Work
 01020 Allowances
 01025 Measurement and Payment
 01030 Alternates/Alternatives
 01035 Modification Procedures
 01040 Coordination
 01050 Field engineering
 01060 Regulatory Requirements
 01070 Identification systems
 01090 References
 01100 Special Project Procedures
 01200 Project Meetings
 01300 Submittals
 01400 Quality Control
 01500 Construction Facilities and Temporary Controls
 01600 Material and Equipment
 01650 Facility Startup/Commissioning
 01700 Contract Closeout
 01800 Maintenance

Division 2 - Site Work

02010 Subsurface Investigation
 02050 Demolition
 02100 Site Preparation
 02140 Dewatering

02150 Shoring and Underpinning
 02160 Excavation Support Systems
 02170 Cofferdams
 02200 Earthwork
 02300 Tunneling
 02350 Piles and Caissons
 02450 Railroad Work
 02480 Marine Work
 02500 Paving and Surfacing
 02600 Utility Piping Materials
 02660 Water Distribution
 02680 Fuel and Steam Distribution
 02700 Sewerage and Drainage
 02760 Restoration of Underground Pipe
 02770 Ponds and Reservoirs
 02780 Power and Communications
 02800 Site Improvements
 02900 Landscaping

Division 3 - Concrete

03100 Concrete Framework
 03200 Concrete Reinforcement
 03250 Concrete Accessories
 03300 Cast-In-Place Concrete
 03370 Concrete Curing
 03400 Precast Concrete
 03500 Cementitious Decks and Toppings
 03600 Grout
 03700 Concrete Restoration and Cleaning
 03800 Mass Concrete

Division 4 - Masonry

04100 Mortar and Masonry Grout
 04150 Masonry Accessories
 04200 Unit Masonry
 04400 Stone
 04500 Masonry Restoration and Cleaning
 04550 Refractories
 04600 Corrosion Resistant Masonry
 04700 Simulated Masonry

Division 5 - Metals

05010 Metal Materials
 05030 Metal Coatings

05050 Metal Fastening
 05100 Structural Metal Framing
 05200 Metal Joists
 05300 Metal Decking
 05400 Cold Formed Metal Framing
 05500 Metal Fabrications
 05580 Sheet Metal Fabrications
 05700 Ornamental Metal
 05800 Expansion Control
 05900 Hydraulic Structures

Division 6 - Wood and Plastics

06050 Fasteners and Adhesives
 06100 Rough Carpentry
 06130 Heavy Timber Construction
 06150 Wood and Metal Systems
 06170 Prefabricated Structural wood
 06200 Finish Carpentry
 06300 Wood Treatment
 06400 Architectural Woodwork
 06500 Structural Plastics
 06600 Plastic Fabrications
 06650 Solid Polymer Fabrications

Division 7 - Thermal and Moisture Protection

07100 Waterproofing
 07150 Dampproofing
 07180 Water Repellents
 07190 Vapor Retarders
 07195 Air Barriers
 07200 Insulation
 07240 Exterior Insulation and Finish Systems
 07250 Fireproofing
 07270 Firestopping
 07300 Shingles and Roofing Tiles
 07400 Manufactured Roofing and Siding
 07480 Exterior Wall Assemblies
 07500 Membrane Roofing
 07570 Traffic Coatings
 07600 Flashing and Sheet Metal
 07700 Roof Special Ties and Accessories
 07780 Skylights
 07790 Joint Sealers

Figure 1.6: MasterFormat coding system

Production activities: activities that involve the use of resources such as labor, equipment, material, or subcontractor. This type of activities can be easily identified by reading the project’s drawings and specifications. Examples are: excavation, formwork, reinforcement, concreting, etc. each production activity can have a certain quantity of work, resource needs, costs, and duration.

Procurement activities: activities that specify the time for procuring materials or equipment that are needed for a production activity. Examples are: brick procurement, boiler manufacturing and delivery, etc.

Management activities: activities that are related to management decisions such as approvals, vacations, etc.

An activity can be as small as “steel fixing of first floor columns” or as large as “construct first floor columns”. This level of details depends on the purpose of preparing the project plan. In the pre construction stages, less detailed activities can be utilized, however, in the construction stages, detailed activities are required. Accordingly, level of details depends on: planning stage, size of the project, complexity of the work, management expertise.

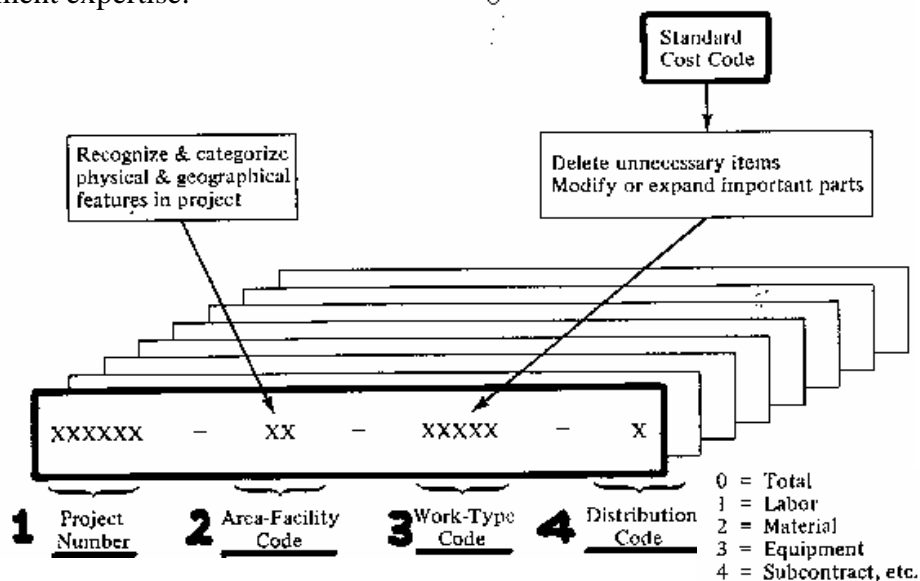

Figure 1.7: An example of an activity coding system

Example 1.2:

Figure 1.8 shows a double-span bridge. Break the construction works of the bridge into activities. The plan will be used for bidding purposes.

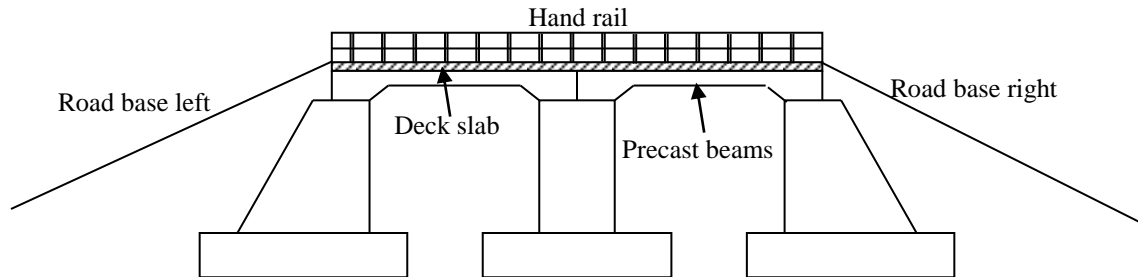

Figure 1.8: Double span bridge

A list of the double-span bridge activities is shown in Table 1.1.

Table 1.1: Activities of the double-span bridge

Activity	Description
10	Set-up site
14	Procure reinforcement
16	Procure precast beams
20	Excavate left abutment
30	Excavate right abutment
40	Excavate central pier
50	Foundation left abutment
60	Foundation right abutment
70	Foundation central pier
80	Construct left abutment
90	Construct right abutment
100	Construct central pier
110	Erect left precast beams
120	Erect right precast beams
140	Fill left embankment
150	Fill right embankment
155	Construct deck slab
160	Left road base
170	Right road base
180	Road surface
190	Bridge railing
200	Clear site

1.2.3 Activities Relationships

In order to identify the relationships among activities, the planning team needs to answer the following questions for each activity in the project:

- Which activities must be finished before the current one can start?
- What activity(ies) may be constructed concurrently with the current one?
- What activity(ies) must follow the current one?

A circle of activity precedence will result in an impossible plan. For example, if activity A precedes activity B, activity B precedes activity C, and activity C precedes activity A, then the project can never be started or completed. [Figure 1.9](#) illustrates the resulting activity network.

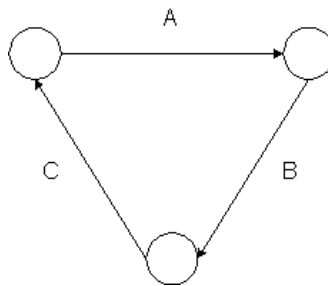

Figure 1.9: Example of a circle of activity precedence

Example 1.3:

Suppose that a site preparation and concrete slab foundation construction project consists of nine different activities:

- A. Site clearing (of brush and minor debris),
- B. Removal of trees,
- C. General excavation,
- D. Grading general area,
- E. Excavation for utility trenches,
- F. Placing formwork and reinforcement for concrete,
- G. Installing sewer lines,
- H. Installing other utilities,
- I. Pouring concrete.

Activities A (site clearing) and B (tree removal) do not have preceding activities since they depend on none of the other activities. We assume that activities C (general excavation) and D (general grading) are preceded by activity A (site clearing). It might also be the case that the planner wished to delay any excavation until trees were removed, so that B (tree removal) would be a precedent activity to C (general excavation) and D (general grading). Activities E (trench excavation) and F (concrete preparation) cannot begin until the completion of general excavation and grading, since they involve subsequent excavation and trench preparation. Activities G (install lines) and H (install utilities) represent installation in the utility trenches and cannot be attempted until the trenches are prepared, so that activity E (trench excavation) is a preceding activity. We also assume that the utilities should not be installed until grading is completed to avoid equipment conflicts, so activity D (general grading) is also preceding activities G (install sewers) and H (install utilities). Finally, activity I (pour concrete) cannot begin until the sewer line is installed and formwork and reinforcement are ready, so activities F and G are preceding. Other utilities may be routed over the slab foundation, so activity H (install utilities) is not necessarily a preceding activity for activity I (pour concrete). The result of our planning is the immediate precedence shown in [Table 1.2](#).

Table 1.2: Precedence relations for Example 1.3

Activity	Description	Predecessors
A	Site clearing	---
B	Removal of trees	---
C	General excavation	A
D	Grading general area	A
E	Excavation for utility trenches	B,C
F	Placing formwork and reinforcement for concrete	B,C
G	Installing sewer lines	D,E
H	Installing other utilities	D,E
I	Pouring concrete	F,G

Example 1.4:

Determine the relationships between activities of the project studied in Example 1.2.

Table 1.3: Solution of Example 1.4

Activity	Description	Predecessors
10	Set-up site	---
14	Procure RFT	---
16	Procure P.C. Beams	---
20	Excavate left abutment	10
30	Excavate right abutment	10
40	Excavate central pier	10
50	Foundation left abutment	14, 20
60	Foundation right abutment	14, 30
70	Foundation central pier	14, 40
80	Construct left abutment	50
90	Construct right abutment	60
100	Construct central pier	70
110	Erect left P.C. Beams	16, 80, 100
120	Erect right P.C. Beams	16, 90, 100
140	Fill left embankment	80
150	Fill right embankment	90
155	Construct deck slab	110, 120
160	Left road base	140
170	Right road base	150
180	Road surface	155, 160, 170
190	Bridge railing	155
200	Clear site	180, 190

Logical relationship considering resource constraints

For efficient use of resources or in case of constrained resources, it might be beneficial to consider the resources when determining the logical relationship among the activities that use the same resources. For example, consider the case of construction a simple project consists of three units and each unit has three sequential activities (logical relationship).

Table 1.4 shows the logical relationship among these activities assuming unconstrained (resources are available with any quantities) and constrained resources (only one resource unit is available from each resource type).

Table 1.4: Logical relationships considering constrained and unconstrained resources

Activity	description	Predecessors (unconstrained resources)	Predecessors (constrained resources)
A1	Excavate unit 1	-	-
B1	Concreting unit 1	A1	A1
C1	Brickwork unit 1	B1	B1
A2	Excavate unit 2	-	A1
B2	Concreting unit 2	A2	B1, A2
C2	Brickwork unit 2	B2	C1, B2
A3	Excavate unit 3	-	A2
B3	Concreting unit 3	A3	B2, A3
C3	Brickwork unit 3	B3	C2, B3

Overlap or lag

Overlap between activities (negative lag) is defined as how much a particular activity must be completed before a succeeding activity may start. The absence of overlap means that the first activity must finish before the second may start. A negative overlap (lag) means a delay is required between the two activities (Figure 1.10)

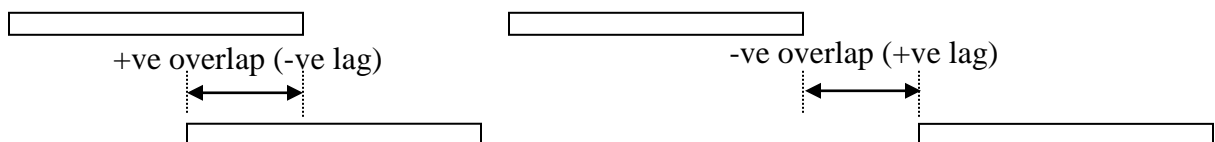

Figure 1.10: Overlap among activities

Example 1.5:

This case study is for a small 3 houses project. The main segments of a single house, the responsibilities, and the logical relationship are identified as follows:

- 11 work packages are involved: A and B (civil work, substructure), C, D, E, and F (civil work, superstructure), G (electrical, interior), H (electrical, exterior), I (mechanical, HVAC), J (mechanical, elevator), and K (mechanical, plumbing).
- Substructure is supervised by Ahmed (activity A), and Ali (activity B).
- Superstructure is supervised by Hossam (activities C and F) and Mona (activities D and E).
- All electrical work is supervised by George.
- HVAC and plumbing are supervised by Adam; elevator work is supervised by Samy.
- Activities E and F follow activity B.
- Activity C precedes activity G.
- Activity I follows the completion of activity E.
- The predecessors to activity K are activities H and I.
- Activity D follows activity A and precedes activity H.
- Activity J is preceded by activities F and G.

It is required to create a WBS and OBS chart.

Solution

From the available information, the relationship table, the network diagrams, and the WBS linked to an OBS are formed as shown below ([Table 1.5](#) and [Figure 1.11](#)).

Table 1.5: Logical relationships of Example 1.5

Activity	Predecessors
Start	-
A	Start
B	Start
C	Start
D	A
E	B
F	B
G	C
H	D
I	E
J	F, G
K	H, I
Finish	J, K

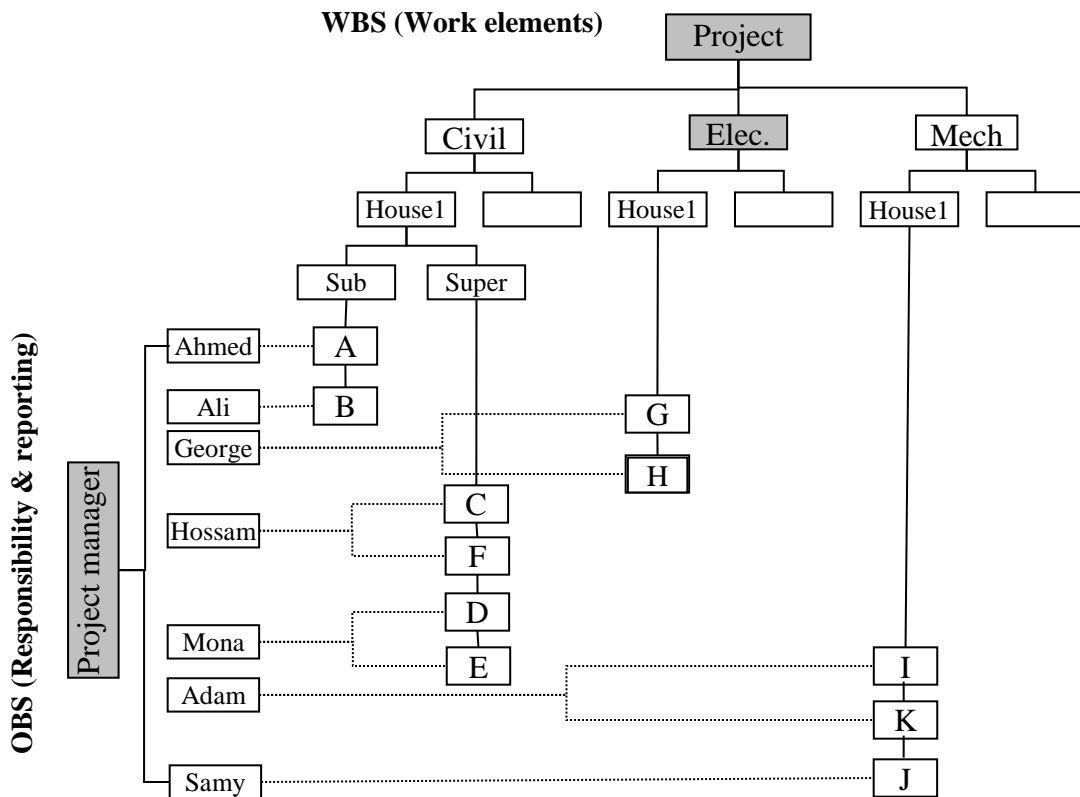

Figure 1.11: WBS and OBS of Example 3.5

Types of activities relationships

Four types of relationships among activities can be defined as described and illustrated below (Figure 1.12). Typically, relationships are defined from the predecessor to the successor activity.

- a) Finish to start (FS). The successor activity can begin only when the current activity completes.
- b) Finish to finish (FF). The finish of the successor activity depends on the finish of the current activity.
- c) Start to start (SS). The start of the successor activity depends on the start of the current activity.
- d) Start to finish (SF). The successor activity cannot finish until the current activity starts.

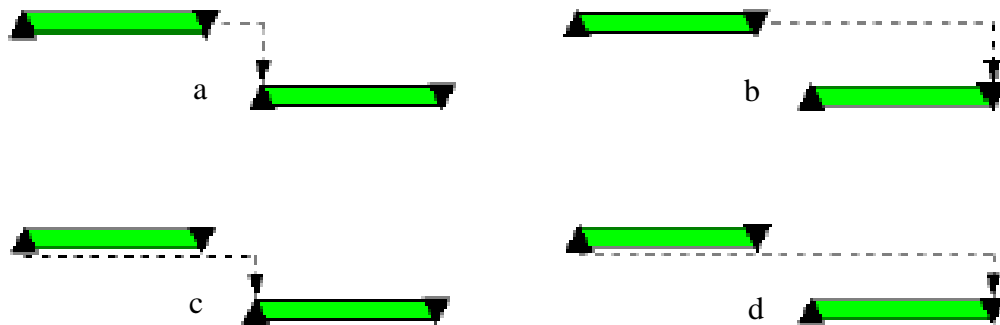

Figure 1.12: Types of relationships

1.2.4 Drawing Project Network

A network is a graphical representation of the project activities and their relationships. A project network is a set of arrows and nodes. Before drawing the network, it is necessary to ensure that the project has a unified starting and ending point. The need for this start activity arises when there is more than one activity in the project that has no predecessors and the end activity is needed when there is more than one activity that has no successors. Also, networks should be continuous (i.e., each activity except the first and the last has both preceding and succeeding activities).

There are two ways that are commonly used to draw a network diagram for a project:

1. Activity on Arrow (AOA) representation.
2. Activity on Node (AON) representation

Activity on arrow network (AOA)

In this method, the arrows represent activities while the nodes represent the start and the end of an activity (usually named as events) (Figure 1.13). The length of the arrow connecting the nodes has no significance and may be straight, curved, or bent. When one activity depends upon another, both appear on the diagram as two arrows having a common node.

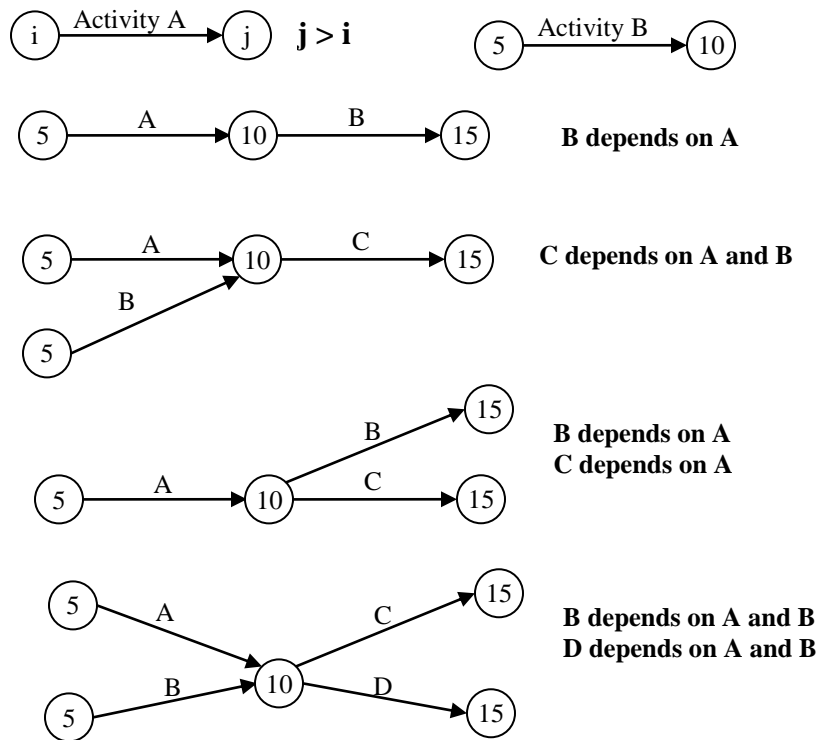

Figure 1.13: Basic patterns of AOA diagrams

The following are some rules that need to be followed when constructing an AOA network diagram:

- Each activity must have a unique $i - j$ numbers, where i (the number at the tail of the arrow) is smaller than j (the number at the head of the arrow).
- It is recommended to have a gap between numbers (i.e., 5, 10, 15, etc.). This will allow for accommodation of missed activities.
- Avoid back arrows.

In some situations, when more than one arrow leaves the same node and arrive at another node, dummy activities must be used. The dummy activity is an activity with zero duration, consumes no resources, drawn as dashed lines, and used to adjust the network diagram. A dummy activity is also used when one activity depends upon two preceding activities and another activity depends only upon one of these two preceding activities as shown in [Figure 1.14](#).

Activity on node network (AON)

This method is also called the precedence diagram method. In this method, the nodes represent activities and the arrows represent logical relationships among the activities. If the arrow starts from the end side of an activity (activity A) and ends at the start side of another activity (activity B), then A is a predecessor of B ([Figure 1.15](#)). AON representation allows the overlap or lag representation on the relationship arrows connecting activities.

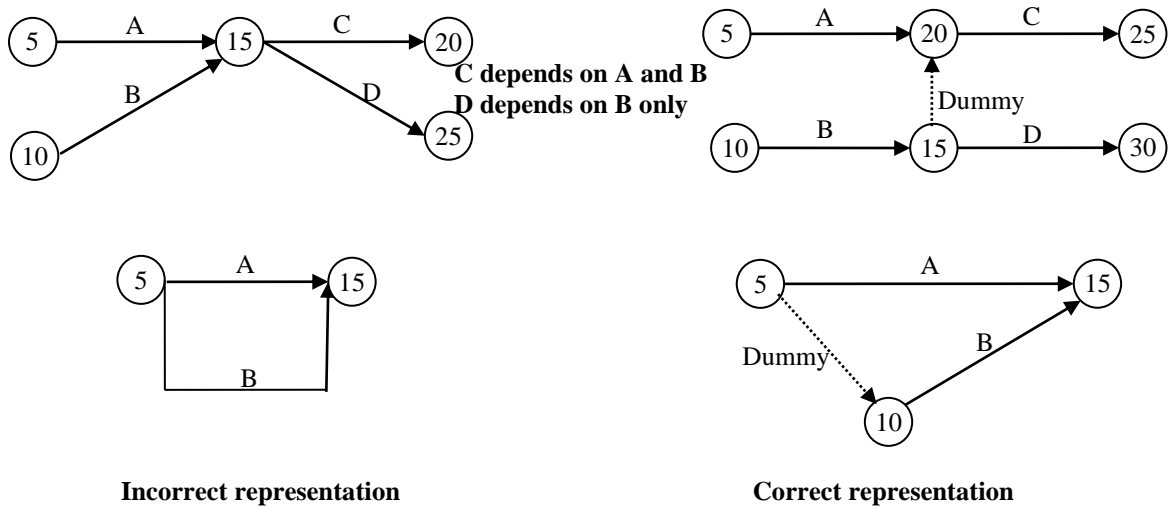

Figure 1.14: Use of dummy activity

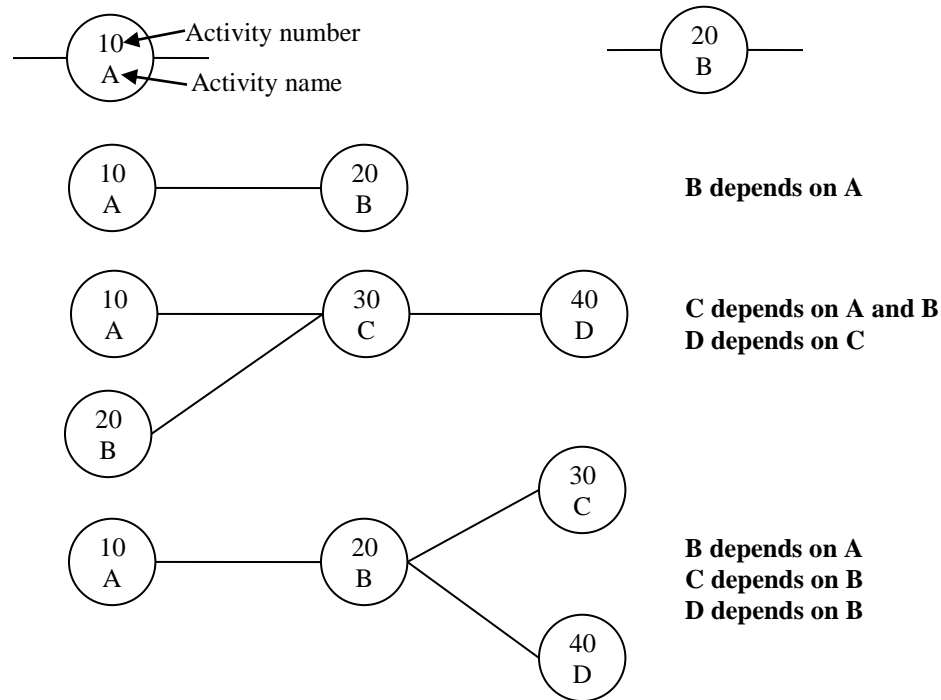

Figure 1.15: Basic patterns of AON diagrams

Comparison between AOA and AON

While both networks can be used to represent a project network, there are some differences between them:

- There is no need for the use of dummy activities in AON representation.
- AON are more easily to draw and to read.
- In AOA, an activity can only start when all its predecessors have finished.
- AON allows for overlap/lag representation.
- AON allows for the representation of the four types of relationships while AOA allows only for the finish to start relationship.

Example 1.6:

Construct an AOA and AON networks for the activities listed in [Table 1.6](#).

Table 1.6: Data for Example 1.6

Activity	Predecessors
A	-
B	-
C	A, B
D	C
E	C
F	D
G	D, E

Forming an AOA network for this set of activities might begin by drawing activities A, B and C as shown in Figure 1.16 (a). At this point, we note that two activities (A and B) lie between the same two event nodes; for clarity, we insert a dummy activity X and continue to place other activities as in Figure 1.16 (b). Placing activity G in the figure presents a problem, however, since we wish both activity D and activity E to be predecessors. Inserting an additional dummy activity Y along with activity G completes the activity network, as shown in Figure 1.16 (c).

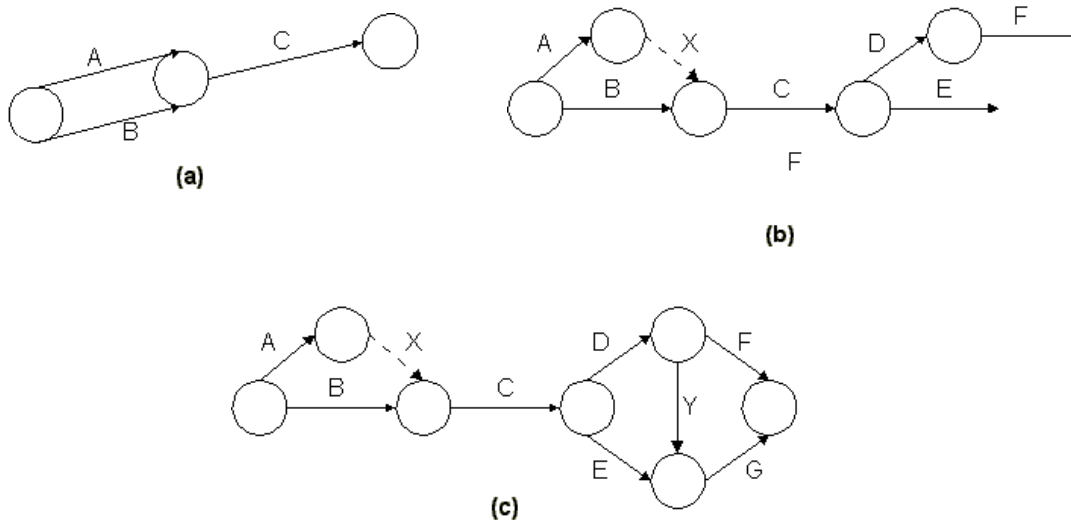

Figure 1.16: AOA Network for Example 1.6

To understand the drawing of the AON, some ordering for the activities may be necessary. This is done by placing the activities in a sequence step order. A sequence step may be defined as the earliest logical position in the network that an activity can occupy while maintaining the logical relationships. In this example, as there are two activities (activities A and B) has no predecessor, then a start activity is added to have one unified start activity (Start) for the project. Also, a finish activity (Finish) is added as there are two activities without successors (activities F and G).

Considering the data given in [Table 1.6](#), sequence step 1 is assigned to the Start activity. Then, we take all activities on the list one by one and look at their immediate predecessors and then assign a sequence step that equals the highest sequence step of all immediate predecessors plus one as given in [Table 1.7](#). After all sequence step numbers have been assigned, the AON diagram can be drawn.

Table 1.7: Determining the sequence steps

Activity	Predecessors	Sequence step (SS)
Start	-	$SS(\text{Start})=1$
A	Start	$2=SS(\text{Start})+1$
B	Start	$2=SS(\text{Start})+1$
C	A, B	$3=\text{Highest of } [SS(\text{B}), SS(\text{A})]$
D	C	$4=SS(\text{C})+1$
E	C	$4=SS(\text{C})+1$
F	D	$5=SS(\text{D})+1$
G	D, E	$5=\text{Highest of } [SS(\text{D}), SS(\text{E})]$
Finish	F, G	$6= \text{Highest of } [SS(\text{F}), SS(\text{G})]$

AON representation is shown in [Figure 1.17](#), including project start and finish nodes. Note that dummy activities are not required for expressing precedence relationships in activity-on-node networks.

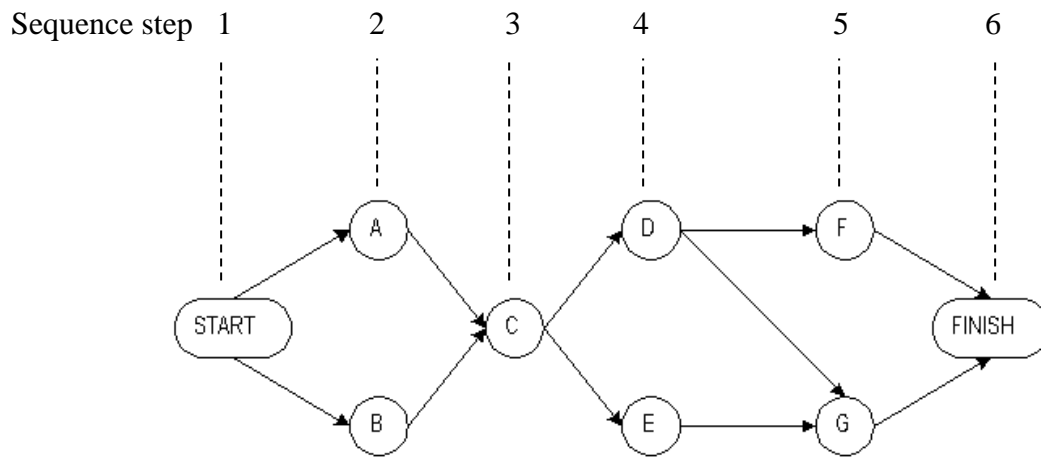

Figure 1.17: An AON Network

Example 1.7

Draw the AOA and AON networks for the project given in Example 3.5.

Solution

The AOA is given in [Figure 1.18](#) and the AON is given in [Figure 1.19](#) as shown below.

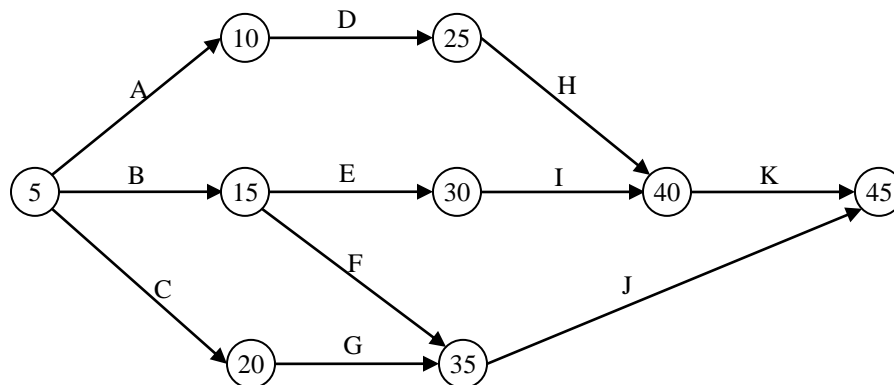

Figure 1.18: AOA network

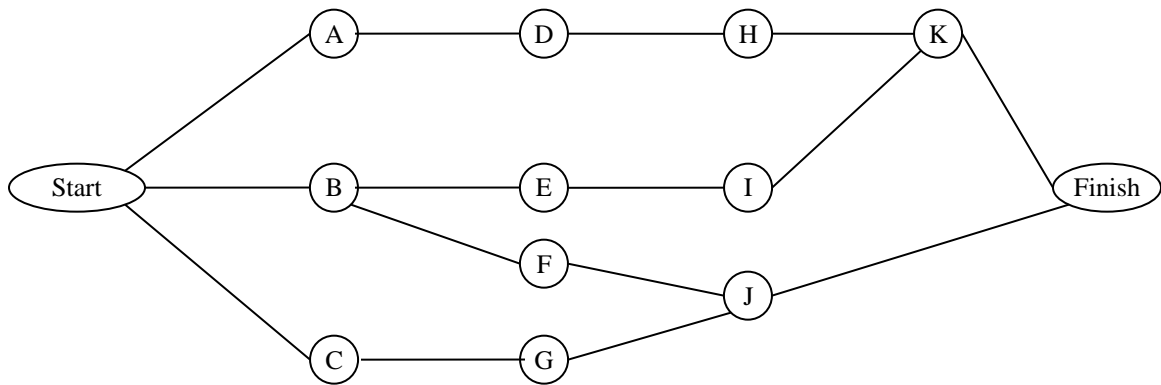

Figure 1.19: AON network

1.3 Estimating Activity Duration and Direct Cost

Having defined the work activities, each activity has associated time duration. These durations are used in preparing a schedule. For example, suppose that the durations shown in [Table 1.8](#) were estimated for a project. The entire set of activities would then require at least 3 days, since the activities follow one another directly and require a total of $1.0 + 0.5 + 0.5 + 1.0 = 3$ days.

Table 1.8: Durations and predecessors for a four-activity project

Activity	Predecessor	Duration (Days)
Excavate trench	---	1.0
Place formwork	Excavate trench	0.5
Place reinforcing	Place formwork	0.5
Pour concrete	Place reinforcing	1.0

All scheduling procedures rely upon estimates of the durations of the various project activities as well as the definitions of the predecessor relationships among activities. A straightforward approach to the estimation of activity durations is to keep historical records of particular activities and rely on the average durations from this experience in making new duration estimates. Since the scope of activities is unlikely to be identical

between different projects, unit productivity rates are typically employed for this purpose. The duration of an activity may be estimated as:

$$\text{Activity duration} = \text{quantity of work} / \text{number of crews} \times \text{resource output}$$

Typically, the quantity of work is determined from engineering drawings of a specific project. The number of crews working is decided by the planner. In many cases, the number or amount of resources applied to particular activities may be modified in light of the resulting project plan and schedule. Some estimate of the expected work productivity must be provided. Historical records in a firm can also provide data for estimation of productivities.

Having defined an activity duration, it means that the planner have already defined the number of resources that will be employed in a particular activity. Knowing activity duration and resources employed, it is simple to estimate the activity direct cost. Then, the three elements of an activity: duration, cost, and resources form what is called construction method. Some activities can be performed using different construction methods. Where, its method will have its own resources, cost and duration.

Example 1.8:

If the daily production rate for a crew that works in an activity is 175 units/day and the total crew cost per day is LE 1800. The material needed for daily work is 4.5 units at LE 100/unit.

- a. Calculate the time and cost it takes the crew to finish 1400 units
- b. Calculate the total unit cost. Consider an eight-hour work day.

Solution

a. Duration (units of time) = Quantity / Production per unit of time x number of crews
= 1400 / 175 x 1 = 8 days

Cost (labor cost) = Duration (units of time) x crew cost per unit of time

$$= 8 \text{ days} \times \text{LE } 1800 / \text{day} = \text{LE } 14400$$

$$\begin{aligned} \text{Total direct cost} &= \text{Le } 14400 + 4.5 \text{ units of material} \times \text{LE } 100 / \text{day} \times 8 \text{ days} \\ &= \text{LE } 18000 \end{aligned}$$

b. Unit cost = total cost / quantity
= LE 18000 / 1400 = LE 12.86 / unit

Sometimes the productivity of a specific crew expressed in man-hours/unit not units/day. For example, if the productivity is said to be 0.5 Man-hour/cubic meters, this means how long it will take one labor to construct one unit. This way applied to any crew formation and work hours.

Example 1.9:

What is the duration in days to install 6000 square feet of walls shuttering if:

- a. Crew of 2 carpenters is used with output of 200 square feet/day
- b. Productivity is measured as 0.008 man-hour/square feet. Number of carpenters =3, and number of working hours/day = 8 hours

Solution

- a. Duration = 6000 / 200 = 3 days
- b. Total man-hours needed = 6000 x 0.008 = 48 man-hours (if one man used)
Duration = 48 / 8 = 6 days (if one man used)
Duration using 3 men = 6 / 3 = 2 days

Example 1.10: (use of several resources)

The construction of a reinforced concrete wall involves placing 660 m³ concrete, fixing 50 ton of steel, and 790 m² of formwork. The following information belongs to the jobs involved in this activity:

- A 6-man concrete crew can place 16 m³ of concrete/day.
- A steel-fixer and assistant can fix 0.5 ton of reinforcement/day.
- A carpenter and assistant can fix and remove 16 m² of shuttering/day.

Calculate the duration of the activity considering the steel-fixer as the critical resource.

Solution

- using one steel-fixer: duration = $50 / 0.5 = 100$ days
- using one carpenter: duration = $790 / 16 = 49.4$ days
- using one concreting crew: duration = $660 / 16 = 41.25$ days.

Then, for a balanced mix of resources, use 2 steel-fixer crews, one carpenter crew, and one concreting crew. Accordingly, the activity duration = $50 / 0.5 \times 2 = 50$ days.

1.4 Exercises

1. Select the right answer:

I. The elements of construction project planning are:

- a. Time
- b. Resources
- c. Cost
- d. All

II. Which of the following is not a typical activity category?

- a. Production
- b. Procurement
- c. Administrative
- d. None of the above

2. In developing the WBS for a project, level of details depends on:,.....,.....

3. List four main differences between AOA and AON networks.

4. A small single-story commercial building is to be constructed on the site of an existing old structure. The exterior and interior walls are of concrete blocks. The roof is erected from steel members covered with rigid insulation and build-up roofing. The ceiling is of suspended tile. The floor is a concrete slab on grade with an asphalt tile finish. Interior finish on all walls is paint. The project has been broken down into 18 steps with construction time estimate has been made for each step. These steps are not given in any particular order. Specify the predecessors of each activity.

- Under ground services (water and sewage services), 1 day.
- Exterior walls, 6 days.
- Demolition, 2 days.
- Interior walls, 3 days.
- Floor slab, 3 days.
- Rough plumbing, 3 days.
- Rough electrical, 3 days.
- Rough carpentry, 2 days.
- Ceiling, 3 days.
- Painting, 1day.
- Foundations, 3 days.
- Roof steel, 2 days.
- Roof finishing, 2 days.
- Floor finishing, 2 days.
- Finish plumbing, 4 days.
- Finish electrical, 3 days.
- Finish carpentry, 4 days.
- Windows, 1day.

5. Prepare a complete plan for the project described below. This project calls for the contractor to construct a temporary two-span, Bypass Bridge for use while a permanent bridge is being replaced. The following figure contains a sketch of the project.

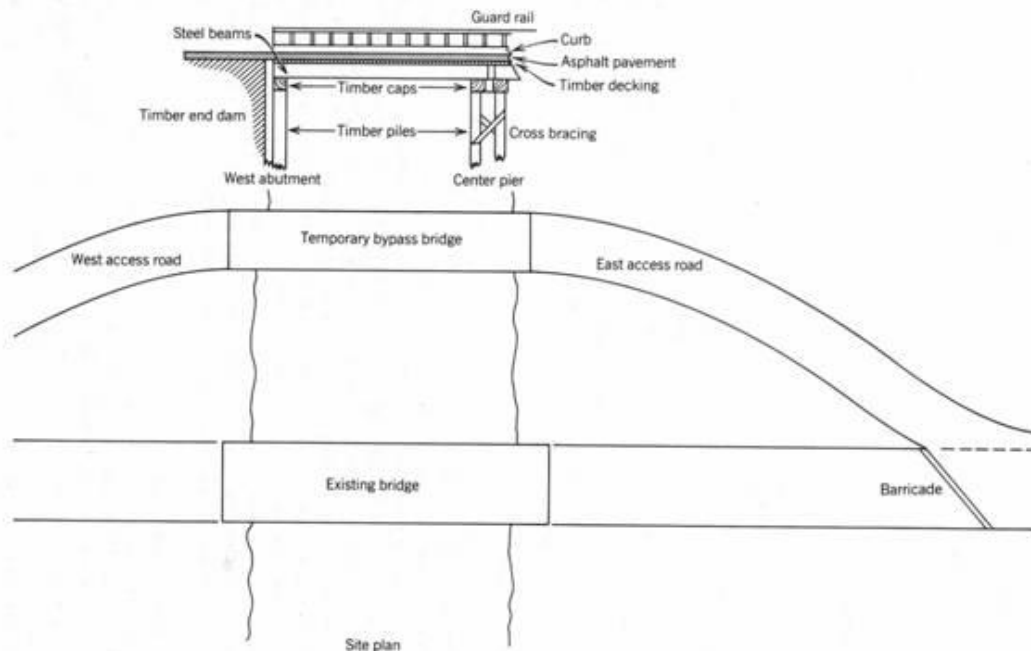

Scope of Work: The Bridge's substructure will include two abutments and a midstream pier. The abutments will be constructed by driving a row of timber

piles. Heavy planks will be spiked to the shore side of these piles to act as a retaining wall. A heavy timber will be placed on top of the row of piles as an abutment cap. The pier will be constructed by driving two rows of timber piles. Heavy timbers will be fastened on top of these piles to serve as the pier cap. The superstructure will consist of steel beams supported by the abutment and pier caps. Timber decking will be secured to the steel beams to serve as the roadway. Miscellaneous bracing, curbs, and guard rails will be installed to complete the bridge. It will be necessary to construct an asphalt concrete access road at both ends of the temporary bridge and to demolish that access road once the bypass bridge is removed. The scope of this project does not include removal of the bypass bridge or its access roads.

Planned Work Sequence: Only one pile-driving rig is available. It is not possible to drive this rig across the existing bridge, and it is not feasible to detour around the bridge; therefore, all piles must be driven from one side of the stream. All other equipment needed for construction can cross over the existing bridge. Work will start with the construction of the access road to the east bank pier. This access road will not be paved until pile driving is completed. Next, the piles will be driven for the east bank abutment, and the east bank abutment will be completed. Then, the midstream piles will be driven from the east bank. When the east bank abutment is completed and when the caps have been installed on the midstream pier, the steel beams will be placed for the east span. After the east span decking is installed, the pile driver can be moved onto the east span and the west bank piles can be driven. Equipment other than the pile driver can be driven across the existing bridge to the west bank; therefore, construction of the west bank access road can be started as soon as the equipment is released from the same task on the east bank.

Task Definition: The tasks shown in the following table have been defined. Task durations were estimated on the basis of an eight-hour workday.

Task No.	Description	Estimated Duration (days)
1	Survey and layout	1
2	Rough-grade access road on east bank	2
3	Drive timber piles for east abutment	1
4	Construct east abutment	5
5	Drive timber piles for midstream pier	2
6	Complete midstream pier	5
7	Place steel girders east span	2
8	Place timber decking east span	2
9	Drive timber piles west abutment	1
10	Construct west abutment	5
11	Place steel girders west span	2
12	Place timber decking west span	2
13	Rough-grade access road on west bank	2
14	Finish grading access road east bank	1
15	Finish grading access road west bank	1
16	Pave access roads both banks	3
17	Install curbs and gutters on bridge	5
18	Stripe access road	1
19	Erect barricades to site of permanent bridge	1

6. Draw a PDM network for a project with the following activities. Show all steps including removing redundant relations; and sequence steps.

- Activity B depends on A;
- Activity G follows E, F & D;
- Activity E depends on B and A;
- Activity F can start when D & B are completed;
- Activity C is followed by F and follows A;
- Activity D is dependent upon A and B.

7. Consider the following set of activities:

Code	Description
A	Layout foundation
B	Excavation
C	Obtain concrete materials
D	Place concrete
E	Obtain steel reinforcement
F1	Cut and bend reinforcement (part 1)
F2	Cut and bend reinforcement (part 2)
G1	Place reinforcement (part 1)
G2	Place reinforcement (part 2)
H	Obtain formwork
I	Erect formwork
J	Remove formwork
K	Clean up

A gang of steelfixers is used to cut and bend reinforcement and another gang is used for placing reinforcement. The first part of reinforcement can be placed during formwork erection while the second part should wait for completion of formwork erection. Tabulate the predecessors of each activity and draw AON network.

8. For the network below, prepare a table showing a list of immediate predecessors and immediate successors for each of the activities. Use the $i - j$ node notation for activities.

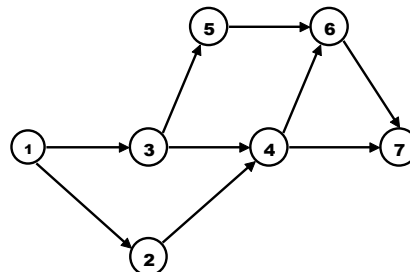

9. The construction of RC wall involves placing 660 m^3 concrete, 50 t of steel, and 790 m^2 of formwork. Calculate the duration of the activity using a balanced mix of the resources if:
- A 6-man concrete gang can place 16 m^3 of concrete / day.
 - One steel fixer and one assistant can fix 0.5 t of steel / day.
 - One carpenter and one assistant can fix and strike 16 m^2 / day.
10. Estimate the labor cost for the formwork of a continuous wall footing that has a quantity of 500 SF. The activity is constructed by crew that has a daily output of 485 SF/day, and consists of: 3 carpenters at rate LE 21.60/hr & 1 building labor at rate LE 17.15/hr.
11. A construction project has the following activities along with their relationships. Develop an Activity on Arrow (AOA) network.
- I. A is the first activity.
 - II. B, C and D follow A and can be done concurrently.
 - III. E and G cannot begin until C is completed, and can be done concurrently.
 - IV. F is the immediate successor to activities B and E.
 - V. H and K run in parallel, and both succeed G.
 - VI. L succeeds F and H.
 - VII. J and I are immediate successor activities to D.
 - VIII. M and N are immediate successor to K and I. However, both M and N can be performed concurrently.
 - IX. Q is the last activity and follows O & P. O is the immediate successor to N and L. Activity P is the immediate successor to M and J.